

0.5" SVGA LC-SD10

**BASIC SERIAL FUNCTIONAL
SPECIFICATION**

-CONTENT-

1. Overview
2. Interface Specification
3. Connection
4. Notes for Communication
5. Functional Execute Command Table
6. Status Read Command Table
7. Functional Execution Command Table
 - 7.1 Format
 - 7.2 When the command pipelining is needed
 - 7.3 Transfer Example
 - 7.4 Operation Requirements
 - 7.5 Power ON Command
 - 7.6 Power OFF Command (Quick POWER OFF)
 - 7.7 Power OFF Command
 - 7.8 Computer Command
 - 7.9 Video Command
 - 7.10 Volume + Command
 - 7.11 Volume – Command
 - 7.12 Audio Mute ON Command
 - 7.13 Audio Mute OFF Command
 - 7.14 Video Mute ON Command
 - 7.15 Video Mute OFF Command
 - 7.16 Screen Normal Size Command
 - 7.17 Screen Wide Size Command
 - 7.18 Image Standard Command
 - 7.19 Image Real Command
 - 7.20 Image Cinema Command
 - 7.21 Image 1 Command
 - 7.22 Image 2 Command
 - 7.23 Image 3 Command
 - 7.24 Image 4 Command
 - 7.25 Menu ON Command
 - 7.26 Menu OFF Command
 - 7.27 Display Clear Command
 - 7.28 Brightness + Command

- 7.29 Brightness – Command
- 7.30 Image (Toggle) Command
- 7.31 Power Management Ready Command
- 7.32 Power Management OFF Command
- 7.33 Power Management Shut Down Command
- 7.34 D.Zoom + Command
- 7.35 D.Zoom - Command
- 7.36 Video Auto Command
- 7.37 Video Video Command
- 7.38 Video S-Video Command
- 7.39 Pointer Right Command
- 7.40 Pointer Left Command
- 7.41 Pointer Up Command
- 7.42 Pointer Down Command
- 7.43 Enter Command
- 7.44 Freeze ON Command
- 7.45 Freeze OFF Command
- 7.46 Computer Analog RGB Command
- 7.47 Computer Scart Command
- 7.48 Computer Component Command
- 7.49 Page Up Command
- 7.50 Page Down Command
- 7.51 Auto PC Adj. Command
- 7.52 Presentation Timer Command
- 7.53 Keystone Up Command
- 7.54 Keystone Down Command
- 8. State Read Command
 - 8.1 Format
 - 8.2 Transfer Example
 - 8.3 Status Read Command
 - 8.4 Input Mode Read Command
 - 8.5 Lamp Time Read Command
 - 8.6 Setting Read Command

1. Overview

- 1.1 This Specification defines projector control commands for LC-SD10 (0.5"SVGA model).
- 1.2 The projector control commands are for controlling projector through RS232C from a computer.

2. Interface Specification

	Specification
Shynchro system	Asynchronous
Transmission Speed	9600 / 19200
Data Length	8 bit
Parity	None
Stop Bit	1
Flow Control	None

1. Transfer rate: initial setting value is 19200
2. Transfer rate can be changed by service mode

3. Connection

Dedicated serial cable that comes with the projector must be used for a connection to a computer and a projector.

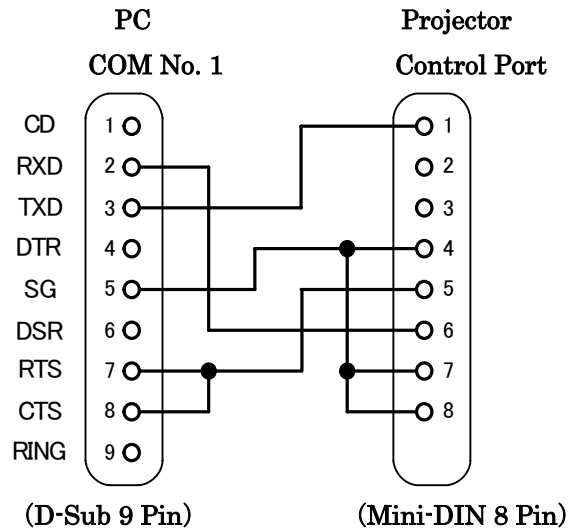

4. Notes for Communication

4.1 The projector command is defined one command/one line that starts “C” and ends carriage return (0x0D).

4.2 The projector starts decoding after the carriage return.

4.3 There are two types of command, functional execution commands and state read commands.

Example of Functional Execution Command: “C05” [CR]

Example of State Read Command: “CR0” [CR]

4.4 It clears information of accepting buffer as following terms.

4.4.1 When a projector receives LF (0x0A) or EOF (0x1A)

4.4.2 When it takes more than one second to receive on e command.

(Until the projector receives the carriage return after the projector receives the first data.)

4.5 When control command pipelining, after the response, wait interval of time as below.

1.COMMAND such as ”VOLUME +/-“→ 100ms

2.Other COMMAND→ 500ms

4.6 Wait at least 500 ms after the response, when status read command pipelining.

4.7 Do not issue any command before the Response.

When there is no response after 5 seconds, issue next command.

4.8 It takes about 7 seconds for internal initialization after plugging in AC. During this time, it cannot process command. Do not issue any commands.

4.9 7 seconds after StandBy or Power ON, even when a projector receives a command, a computer receives acceptable response, but it does not execute for internal initialization and lamp lighting process. However, Status Read Commands are executed after 500ms when they receive acceptable response.

4.10 About performance during processing count down or cooling down.

When a projector receives After Stand By or Power ON, Even when a projector receives a command, a computer receives response to accept the command, but it does not execute for internal initialization and lamp lighting process. However, Status Read Commands are executed.

4.11 About performance when changing INPUT.

After receiving INPUT switching command, when receiving commands between 5 seconds from starting the switching to completing the switching, a computer receives acceptable command, but it is not executed.

However, status read commands are executed after a computer receives response to accept the command, after 500ms.

Response for Status Read Command after accepting has different characters. See ”Status Read Command Table”.

4.12 Characters for commands must be Capital (A - Z).

5. Functional Execution Command Table

Command	Item	Command	Item
C00	Power ON	C27	Image (Toggle)
C01	Power OFF Quick Power OFF)	C2A	Power Management Ready
C02	Power OFF	C2B	Power Management OFF
C05	Computer	C2E	Power Management Shut down
C07	Video	C30	D.Zoom +
C09	Volume +	C31	D.Zoom -
C0A	Volume -	C32	Video Auto
C0B	Audio Mute ON	C33	Video Video
C0C	Audio Mute OFF	C34	Video S-Video
C0D	Video Mute ON	C3A	Pointer Right
C0E	Video Mute OFF	C3B	Pointer Left
C0F	Screen Normal size (4:3)	C3C	Pointer Up
C10	Screen Wide size (16:9)	C3D	Pointer Down
C11	Image Standard	C3F	Enter
C12	Image Real	C43	Freeze ON
C13	Image Cinema	C44	Freeze OFF
C14	Image 1	C50	Computer Analog RGB
C15	Image 2	C51	Computer Scart
C16	Image 3	C54	Computer Component
C17	Image 4	C59	Page Up
C1C	Menu ON	C5A	Page Down
C1D	Menu OFF	C89	Auto PC Adj.
C1E	Display Clear	C8A	Presentation Timer
C20	Brightness +	C8E	Keystone Up
C21	Brightness -	C8F	Keystone Down

6. Status Read Command Table

Command	Function	
CR0	Status Read	
CR1	Input Mode Read	
CR3	Lamp Time Read	
CR4	Setting Read	
CR6	Temp Read	

7. Functional Execution Command Table

7.1 Format

1. PC issues a command as below form at

“C” COMMAND [CR]

Command: 2 characters (See Functional Execution Command Table)

2. A projector decodes received data and sends a return result after being ready to receive next command.

[ACK][CR]: (0x06,0x0D) When received functional execution commands.

“?”[CR]: When cannot read received data

7.2 When the command pipelining is needed

When some functions need command pipelining , the performance is the same as the remote control's performance.

1. System: issue any commands every 100ms after receiving response
2. When receiving the same command continuously with 120ms, the function is executed for 120ms from that moment.
3. When receiving the same command continuously, with 120ms, the function is executed for 120ms form the moment.
4. The next command is not issued after 120ms, and the execution is stopped.
5. If the projector receives other incoming commands within 120ms, the execution is stopped.

7.3 Transfer Example

Change to Video mode with Basic Command

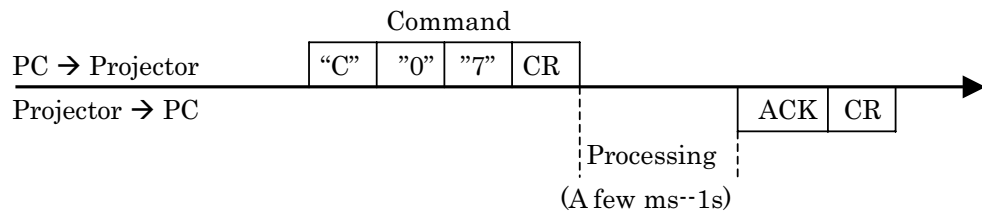

7.4 Operation Requirements

When the projector's status in this below, functional execution commands are limited.

Status Read Commands are available even in this table status.

Projector Status	Available Functional Execution Commands
StandBy Mode	C00: Power ON
Processing Countdown	C00: Power ON (Terminate Countdown)
Processing Cooling Down	N/A
Processing Cooling Down due to abnormal temperature.	N/A
Abnormal Temperature Status	N/A
Processing Mode Change	N/A
Processing Power Save/Cooling Down	N/A
Processing Power Save	C00: Power ON C01: Power OFF

Note) When the status is above, even if the projector receives other command in the above status, the projector returns **[ACK][CR]**.

7.5 Power ON Command

Command	"C00" [CR]	
Detail	Power ON When already Power ON, no need to do. When sending this command during processing Count Down, Count Down is terminated.	
Response	Acceptable	[ACK] [CR]
	Unacceptable	"?" [CR]

7.6 Power OFF Command (Quick Power OFF)

Command	"C01" [CR]	
Detail	Power OFF (Stand By) When Power OFF with ON-OFF button of the projector or the remote control, "Power OFF" will be displayed. However, as soon as this command is sent, Quick Power OFF is executed.	
Response	Acceptable	[ACK] [CR]
	Unacceptable	"?" [CR]

7.7 Power OFF Command

Command	"C02" [CR]	
Detail	Power OFF (Stand By) When Power OFF with ON-OFF button of the projector or the remote control, "Power OFF" will be displayed. However, as soon as this command is sent, Power OFF is executed.	
Response	Acceptable	[ACK] [CR]
	Unacceptable	"?" [CR]

7.8 Computer Command

Command	"C05" [CR]	
Detail	Select Computer input	
Response	Acceptable	[ACK] [CR]
	Unacceptable	"?" [CR]

7.9 Video Command

Command	"C07" [CR]	
Detail	Select Video input.	
Response	Acceptable	[ACK] [CR]
	Unacceptable	"?" [CR]

7.10 Volume+ Command

Command	"C09" [CR]	
Detail	Volume Up This Command works same as "VOLUME +" of the projector and the remote control.	
Response	Acceptable	[ACK] [CR]
	Unacceptable	"?" [CR]

7.11 Volume- Command

Command	"C0A" [CR]	
Detail	Volume Down This Command works same as "VOLUME +" of the projector and the remote control.	
Response	Acceptable	[ACK] [CR]
	Unacceptable	"?" [CR]

7.12 Audio Mute ON Command

Command	"C0B" [CR]	
Detail	Sound Mute ON This command works same as "MUTE" of the projector and the remote control, but this command does not work for MUTE OFF.	
Response	Acceptable	[ACK] [CR]
	Unacceptable	"?" [CR]

7.13 Audio Mute OFF Command

Command	"C0C" [CR]	
Detail	Sound Mute OFF This command works the same as "MUTE" of the Remote Control button for MUTE OFF, but does not work for "MUTE ON"	
Response	Acceptable	[ACK] [CR]
	Unacceptable	"?" [CR]

7.14 Video Mute ON Command

Command	"C0D" [CR]	
Detail	VIDEO MUTE ON This command works same as "NO SHOW" of the remote control, but does not work for "NO SHOW"	
Response	Acceptable	[ACK] [CR]
	Unacceptable	"?" [CR]

7.15 Video Mute OFF Command

Command	"C0E" [CR]	
Detail	VIDEO MUTE OFF This command works the same as "NO SHOW" of remote control button for VIDEO MUT OFF, but does not work for No Show ON".	
Response	Acceptable	[ACK] [CR]
	Unacceptable	"?" [CR]

7.16 Screen Normal size Command

Command	"C0F" [CR]	
Detail	Set video screen size to Regular (4:3)	
Response	Acceptable	[ACK] [CR]
	Unacceptable	"?" [CR]

7.17 Screen Wide size Command

Command	"C10" [CR]	
Detail	Set video screen size to Wide (16:9).	
Response	Acceptable	[ACK] [CR]
	Unacceptable	"?" [CR]

7.18 Image Standard Command

Command	"C11" [CR]	
Detail	Set Image to Standard Mode.	
Response	Acceptable	[ACK] [CR]
	Unacceptable	"?" [CR]

7.19 Image Real Command

Command	"C12" [CR]	
Detail	Set Image to Real Mode.	
Response	Acceptable	[ACK] [CR]
	Unacceptable	"?" [CR]

7.20 Image Cinema Command

Command	"C13" [CR]	
Detail	Set Image to Cinema Mode.	
Response	Acceptable	[ACK] [CR]
	Unacceptable	"?" [CR]

7.21 Image 1 Command

Command	"C14" [CR]	
Detail	Set Image to Image 1 Mode.	
Response	Acceptable	[ACK] [CR]
	Unacceptable	"?" [CR]

7.22 Image 2 Command

Command	"C15" [CR]	
Detail	Set Image to Image 2 Mode.	
Response	Acceptable	[ACK] [CR]
	Unacceptable	"?" [CR]

7.23 Image 3 Command

Command	"C16" [CR]	
Detail	Set Image to Image 3 Mode.	
Response	Acceptable	[ACK] [CR]
	Unacceptable	"?" [CR]

7.24 Image 4 Command

Command	"C17" [CR]	
Detail	Set Image to Image 4 Mode.	
Response	Acceptable	[ACK] [CR]
	Unacceptable	"?" [CR]

7.25 Menu ON Command

Command	"C1C" [CR]	
Detail	Display Menu of On Screen Display	
Response	Acceptable	[ACK] [CR]
	Unacceptable	"?" [CR]

7.26 Menu OFF Command

Command	"C1D" [CR]	
Detail	Clear Menu of On Screen Display	
Response	Acceptable	[ACK] [CR]
	Unacceptable	"?" [CR]

7.27 Display Clear Command

Command	"C1E" [CR]	
Detail	Clear the On Screen Display Clear the On screen Display unconditionally	
Response	Acceptable	[ACK] [CR]
	Unacceptable	"?" [CR]

7.28 Brightness+ Command

Command	"C20" [CR]	
Detail	Brightness of user control +1	
Response	Acceptable	[ACK] [CR]
	Unacceptable	"?" [CR]

7.29 Brightness- Command

Command	"C21" [CR]	
Detail	Brightness of user control -1	
Response	Acceptable	[ACK] [CR]
	Unacceptable	"?" [CR]

7.30 Image (Toggle) Command

Command	"C27" [CR]	
Detail	Switch Image setting status. This command works the same as the remote control's "Image" button or the key on the projector body.	
Response	Acceptable	[ACK] [CR]
	Unacceptable	"?" [CR]

7.31 Power Management Ready Command

Command	"C2A" [CR]	
Detail	Set Power Management to Ready This status is stored in EEPROM, so even if turning off and on.	
Response	Acceptable	[ACK] [CR]
	Unacceptable	"?" [CR]

7.32 Power Management OFF Command

Command	"C2B" [CR]	
Detail	Set Power Management to OFF mode. This status is stored in EEPROM, and even if turning OFF and ON.	
Response	Acceptable	[ACK] [CR]
	Unacceptable	"?" [CR]

7.33 Power Management Shut Down Command

Command	"C2E" [CR]	
Detail	Set Power Management to Shut down mode. This status is stored in EEPROM, and even if turning OFF and ON.	
Response	Acceptable	[ACK] [CR]
	Unacceptable	"?" [CR]

7.34 D.Zoom+ Command

Command	"C30" [CR]	
Detail	Moving on to Digital Zoom Mode and make the screen image bigger. This command works the same as the remote control's "D.ZOOM UP"	
Response	Acceptable	[ACK] [CR]
	Unacceptable	"?" [CR]

7.35 D.Zoom- Command

Command	"C31" [CR]	
Detail	Moving on to Digital Zoom Mode and make the screen image smaller. This command works the same as the remote control's "ZOOM DOWN" button.	
Response	Acceptable	[ACK] [CR]
	Unacceptable	"?" [CR]

7.36 Video Auto Command

Command	"C32" [CR]	
Detail	Select Auto input for Video.	
Response	Acceptable	[ACK] [CR]
	Unacceptable	"?" [CR]

7.37 Video Video Command

Command	"C33" [CR]	
Detail	Select Video input for Video.	
Response	Acceptable	[ACK] [CR]
	Unacceptable	"?" [CR]

7.38 Video S-Video Command

Command	"C34" [CR]	
Detail	Select S-Video input for Video.	
Response	Acceptable	[ACK] [CR]
	Unacceptable	"?" [CR]

7.39 Pointer Right Command

Command	"C3A" [CR]	
Detail	Move Pointer to right On Screen Display. This command works the same as the remote control's ">".	
Response	Acceptable	[ACK] [CR]
	Unacceptable	"?" [CR]

7.40 Pointer Left Command

Command	"C3B" [CR]	
Detail	Move Pointer to left On Screen Display Menu. This command works the same as the remote control's "<".	
Response	Acceptable	[ACK] [CR]
	Unacceptable	"?" [CR]

7.41 Pointer Up Command

Command	"C3C" [CR]	
Detail	Move Pointer to UP On Screen Display This command works the same as the remote control "UP" button.	
Response	Acceptable	[ACK] [CR]
	Unacceptable	"?" [CR]

7.42 Pointer Down Command

Command	"C3D" [CR]	
Detail	Move Pointer to Down On Screen Display This command works the same as the remote control's "DOWN" button.	
Response	Acceptable	[ACK] [CR]
	Unacceptable	"?" [CR]

7.43 Enter Command

Command	"C3F" [CR]	
Detail	This command works the same as the remote control's "SELECT" button.	
Response	Acceptable	[ACK] [CR]
	Unacceptable	"?" [CR]

7.44 Freeze ON Command

Command	"C43" [CR]	
Detail	Make the screen Freeze. This command works the same as the remote control's "FREEZE" button not for Freeze OFF but for Freeze ON	
Response	Acceptable	[ACK] [CR]
	Unacceptable	"?" [CR]

7.45 Freeze OFF Command

Command	"C44" [CR]	
Detail	Return to Freeze OFF screen. This command works the same as the remote control's "FREEZE" button for Freeze off.	
Response	Acceptable	[ACK] [CR]
	Unacceptable	"?" [CR]

7.46 Computer Analog RGB Command

Command	"C50" [CR]	
Detail	Select Analog RGB input for Input 1.	
Response	Acceptable	[ACK] [CR]
	Unacceptable	"?" [CR]

7.47 Computer Scart Command

Command	"C51" [CR]	
Detail	Select Computer Scart input.	
Response	Acceptable	[ACK] [CR]
	Unacceptable	"?" [CR]

7.48 Computer Component Command

Command	"C54" [CR]	
Detail	Select Computer Component input.	
Response	Acceptable	[ACK] [CR]
	Unacceptable	"?" [CR]

7.49 Page Up Command

Command	"C59" [CR]	
Detail	Page Up for PowerPoint when PC and USB are connected.	
Response	Acceptable	[ACK] [CR]
	Unacceptable	"?" [CR]

7.50 Page Down Command

Command	"C5A" [CR]	
Detail	Page Down for PowerPoint when PC and USB are connected.	
Response	Acceptable	[ACK] [CR]
	Unacceptable	"?" [CR]

7.51 Auto PC Adj. Command

Command	"C89" [CR]	
Detail	Execute Auto PC Adj. command This command works the same as a remote control's "AUTO PC ADJ." button. While Auto PC Adj. is working and a computer issues another command, Auto PC Adj. Stops.	
Response	Acceptable	[ACK] [CR]
	Unacceptable	"?" [CR]

7.52 Presentation Timer Command

Command	"C8A" [CR]	
Detail	Set a presentation timer to active. This command works the same as the remote control's "P-TIMER" button.	
Response	Acceptable	[ACK] [CR]
	Unacceptable	"?" [CR]

7.53 Keystone Up Command

Command	"C8E" [CR]	
Detail	Adjust keystone. Make the screen image length at the top edge shorter.	
Response	Acceptable	[ACK] [CR]
	Unacceptable	"?" [CR]

7.54 Keystone Down Command

Command	"C8F" [CR]	
Detail	Adjust keystone. Make the screen image length at the bottom edge shorter.	
Response	Acceptable	[ACK] [CR]
	Unacceptable	"?" [CR]

8. State Read Command

8.1 Format

8.1.1 A PC issues commands in format as below.

"CR" **COMMAND** [CR]

Command: 1 character (See Basic Status Read Command Table)

8.1.2 When a projector receives the appropriate command, it returns a character line as the required data.

Required Data [CR]

Required Data: A character line (See Basic Status Read Command Table)

8.1.3 When receiving data cannot be decode, the projector returns, "???" [CR].

8.2 Transfer Example

Get input mode for the projector by basic commands.

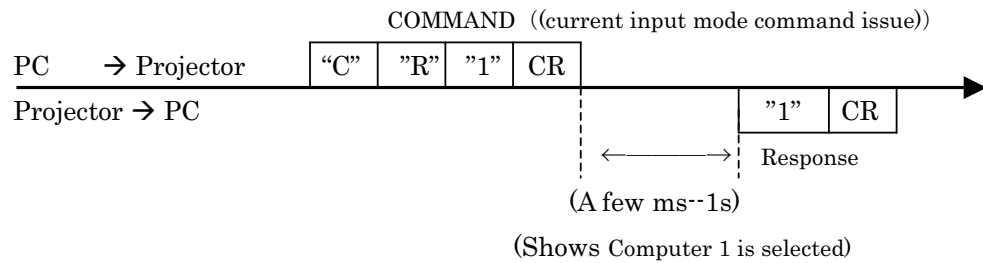

8.3 Status Read Command

Command	"CR0" [CR]	
Detail	Get the projector status	
Response	Acceptable	"%1" [CR]
	%1	"00" = POWER ON "80" = STANDBY "40" = Processing Count Down "20" = Processing Cooling Down "10" = Power Failure "28" = Processing cooling down due to abnormal temperature "08" = Abnormal Temperature "88" = normal after recovering abnormal temperature "02" = cannot accept RS232C command "24" = Processing Power Save · Cooling Down "04" = Power Save
	Unacceptable	"?" [CR]

【Response の Detail】

8.3.1 "00" [CR]

Status: POWER ON

The image is displayed normally.

8.3.2 "80" [CR]

Status: STAND BY

When the status is STAND BY, Status Read Commands are always acceptable, but

Functional Execution Commands are not acceptable except Power ON Command

8.3.3 “40” [CR]

Status: Processing Count Down

When “Display” in Setting Menu is ON and Power ON is executed, it starts processing Count Down.

This Count Down finishes in 60 seconds and moves to Power ON.

During this process, control commands except Power ON Command (“CC00”)[CR] are unacceptable. When Power ON Command is executed, processing Count Down is terminated and the status moves to Power ON. Also, when “Display” OFF in the setting menu is set, processing Count Down is skipped and the status moves to Power ON quickly.

8.3.4 “20” [CR]

Status: Cooling

When status is Power ON, and Power OFF Command is executed, it moves to cooling status.

This cooling status automatically moves on to Stan By after the lamp turns off and the fan spin for about 90seconds.

The time defers from models. This Cooling Down Works for lamps and other optical accessories. Control commands are not available for this status.

8.3.5 “10” [CR]

Status: Abnormal power supply voltage

When the power supply voltage inside the projector reaches abnormal power supply voltage, the power will be automatically turned off. The projector returns “10”[CR] and cooling fan is also stopped at the time.

8.3.6 “28” [CR]

Status: Processing Cooling Down because of critical temperature.

When the temperature inside a projector is out of the operating temperature, it automatically starts cooling down. Response is “28”[CR].

Even if the temperature is processing low, the cooling down is executed

8.3.7 “08” [CR]

Status: Abnormal temperature

When the temperature does not go down after cooling down due to the abnormal temperature, this is the Response. The projector keeps the Standby status.

8.3.8 "88" [CR]

Status: Normal status after recovering abnormal temperature.

When the temperature goes down after cooling down and moving to Standby status, this is the response.

This status keeps until the next operation. In short, when Power On is executed, the temperature information is canceled, and works normal.

8.3.9 "02" [CR]

RS232C Command is unacceptable.

When a computer receives this response, try to execute Status Read Command again.

8.3.10 "24" [CR]

Status: Processing Power Save · Cooling Down

When Power Management function is ON in setting menu and there is no signal for 5 minutes, it moves on to Power Save/Cooling Down after tuning off the lamps.

(During this process, Green LED is OFF.)

The control command is invalid

After this Power Save/Cooling Down continues for about 90 seconds, it moves on to Power Save. (Green LED flashes.)

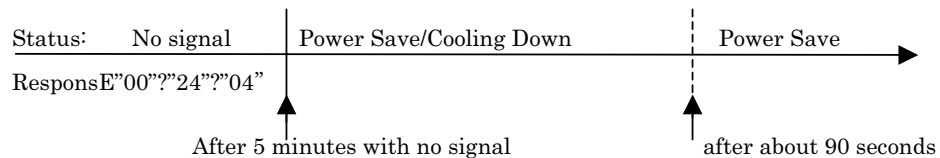

8.3.11 "04" [CR]

Status of Power Save

When the Power Management function is ON in setting menu, and there is no signal for 5 minutes, it moves on to PowerSave status after PowerSave and Cooling Down.

Moving on to the status of Power On is the same action as moving on to the Power On from the status of normal stand by.

- Power ON Command:"C00"[CR] ······move on the status of power on
- Power OFF Command:"C01"[CR] ······move on the status of stand by

Moving on to the status of Power On is the same action as moving on to the Power On from the status of normal stand by.

8.4 Input Mode Read Command

Command	"CR1" [CR]	
Detail	Get selected Input No.	
Response	Acceptable	"%1" [CR]
	%1	"1" = Computer is selected "3" = Video is selected
	Unacceptable	"?" [CR]

8.5 Lamp Time Read Command

Command	"CR3" [CR]	
Detail	Get total lamp running hours.	
Response	Acceptable	"%1" [CR]
	%1	Show as 4 digits Ex.: "0410"[CR] → 410 hours
	Unacceptable	"?" [CR]

8.6 Setting Read Command

Command	"CR4" [CR]	
Detail	Get setting status for screen such as Ceiling/Rear.	
Response	Acceptable	"%1" [CR]
	%1	"11"[CR] = Normal Screen Setting "10"[CR] = Rotation around the horizontal setting (Rear & Ceiling ON) "01"[CR] = Rotation around the horizontal setting Rear ON "00"[CR] = Vertical and right-and left (four directions) reversal setting (status: Ceiling ON)
	Unacceptable	"?" [CR]

8.7 Temp Read Command

Command	"CR6" [CR]	
Detail	Get the temperature inside a projector. When some temperature sensors are installed in the projector, it is possible to know the temperature all at once.	
Response	Acceptable	"%1_%2_%3" [CR]
	%1, %2	<p>%1=Temperature, sensor 1 %2=Temperature, sensor 2 %3=Temperature, sensor 3 Temperature data form shows as 00.0. When the temperature sinks to -, the first character is "-" like "-05.5"[CR]. When cannot return the temperature data due to hardware problems, the first character is "E" like"E00.0"[CR]. When the status is Stand BY or it is 10 seconds after Power On, depend on projectors, temperature may approach critical temperature due to ballast lamp's residual heat. So, when the status is Stand By or it is 10 seconds after Power On, the process for the abnormal temperature is not executed. The temperature data is " ----" at the time. When some temperature sensors are installed, the projector sends command continuously. "_31.5_35.2_33.4"[CR] There is the first sensor's information, and after one space, there is the second sensor's information.</p>
	Unacceptable	"?"[CR]