

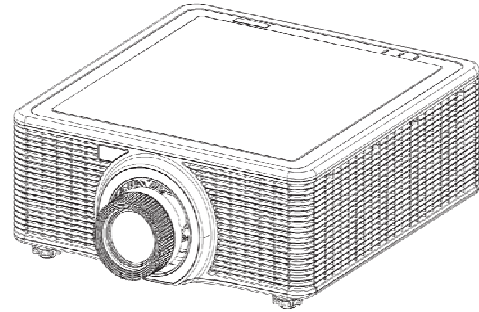

EK-818U

9,500 Lumens / WUXGA / 1-chip DLP®
 Laser (Blue) + Phosphor Light Engine
 "Large Venue" Series Projector
 4K & High Dynamic Range (HDR) Support



EK-818U

9,500 center lumens bright with a 100,000:1 contrast ratio.
 Laser (Blue) + Phosphor Laser Light Engine. 20,000 hour Laser Light source life.
 Native WUXGA resolution. Compatible with inputs up-to UXGA and WUXGA.
 Supports analog and digital video input in all color standards up-to 1080p.
 Supports 4K video input via HDMI, DVI and HDBaseT.
 High Dynamic Range content support for increased contrast and color accuracy.
 Flexible Installation up to 360° and Portrait Projection mode.
 Wired network monitoring and control. Telnet, Crestron, AMX & PJ-Link compatibility.
 Wifi available with optional USB Dongle.
 Horizontal, Vertical, Pin Cushion and 4-Corner Keystone Correction.
 Built-in Picture in Picture and Picture by Picture.
 Filterless IP5X Sealed optical engine design.
 Security bar, Kensington® MicroSaver® security slot. PIN lock.
 3 year projector warranty. 20,000 Laser Light Engine warranty.

Included Accessories:

Quick Start Guide, 5.0 ft. (1.5 m) VGA Cable, 6.0 ft. (1.8 m) Detachable Power Cord, Remote Control (with 2x AAA Batteries), Lens Cover

Optional Accessories:

Ceiling Mount, Ceiling Post and Plate

Specifications: Model EK-818U

Brightness	9,500 Center Lumens	Image Signal Resizing	Smart Scaling Technology
Contrast Ratio	100,000:1	Image Signal Inputs	
Resolution and Aspect Ratio	WUXGA (1920 x 1200), 16:10	Computer 1	Dsub15 x 1
Color Reproduction	10-bit (16.7 million colors)	Digital Video (w/ HDCP)	DVI-D x 1
Projection Light Source	Laser (Blue) + Phosphor	Digital Video (w/ HDCP)	HDMI x 2
Estimated Light Source Life	20,000 hours	HDBaseT	RJ45 x 1
Total Pixels	2,304,000 (1920 x 1200) x 1	3G-SDI	BNC x 1
Imaging System	0.67" DMD™ DLP® chip x 1	3D Sync In	Mini DIN 3 x 1
Scanning Frequency	Auto: H Sync. 15-91 KHz, V Sync. 24-120 Hz	USB Type A - Wifi Dongle	Type A x 1
Pixel Clock	up-to 162 MHz	Outputs	
Lens	Optional Lenses Available - See lens chart on website	Computer Monitor	Dsub15 x 1
Image Diagonal	50-350 in (127-889 cm)	3D Sync Out	Mini DIN 3 x 1
Image Width	3.5-24.75 ft (1.07-7.5 m)	12V Out Trigger	MiniStereo x 1
Throw Distance	2.66-116 ft (0.81-35.36 m)	Fan Noise (@ 1m) Eco / Normal	34 dB / 36dB
Projector Elevation Adjustment (legs)	up-to 5°	Cabinet Size (HxWxD) - excluding legs	7.1 x 19.1 x 20.0 in (18.1 x 48.4 x 50.9 cm)
Maximum Pitch	Up-to 360° Installation	Weight	39.0 lb (17 kg)
Vert/Horiz. Keystone Correction	Digital:V: +/- 20°(Auto) H: +/- 20° (Auto), Corner Keystone	Packaged Cabinet Size (HxWxD)	15.5 x 24.7 x 23.4 in (39.3 x 62.7 x 59.5 cm)
Lens Shift	V: +/- 50% H: +/- 15%	Packaged Weight	
Image Orientation	Normal, Reversed, Inverted	Operating Temperature	41-104°F (5-40°C)
Local Control / Power Management	Full Function / Auto Shutdown	Electrical Safety Compliance	IEC / UL / cUL
Remote Control	Wireless/Wired x 1	Electromagnetic Compatibility	FCC Class B, CE Mark
Wired Remote Port	MiniStereo x 1	Power Requirements	100-240V AC, 50/60 Hz
RS-232 Control Port	Dsub9 x 1	Power Consumption	0.5 W in Eco Standby mode, up-to 650 W
LAN Port	RJ45 x 1	Heat	up-to 2,222 BTU/hr
Computer Input in Pixels	up-to 1600x1200 (4:3), 1920x1200 (16:10)	Security Facilities	Kensington® Security Slot
Analog 4x3 Inputs	UXGA, SXGA+, SXGA, XGA, SVGA, VGA, MAC	UPC	4571194679465
Analog Wide Inputs	WUXGA, WSXGA+, WXGA	User Maintenance	Clean Filter
Digital 4x3 Inputs	UXGA, SXGA+, SXGA, XGA, SVGA, VGA, MAC	Limited Warranty: to the original end use customer only	
Digital Wide Inputs	WUXGA, WSXGA+, WXGA	Projector	*3 years / 6000 hours
Video Formats	NTSC / PAL / SECAM	Laser Light Engine only	20,000 hours
Video Input Analog	480i/p, 575i/p		*(whichever occurs first)
Video Input Digital	480p, 575p, 720p, 1080i/p, 4K*		

EIKI® is a registered trademark of Eiki International Inc. Kensington is a registered trademark of ACCO Brands Corporation.

Specifications subject to change without notice. ©2019 Eiki International Inc. Issued December 5, 2019
 Eiki International Inc., 30251 Esparanza, Rancho Santa Margarita, CA 92688-2132. Tel: 800-242-3454; Fax: 800-457-3454, Email: usa@eiki.com